



SD SERIES FLOOR MOUNT DRYING HOPPERS 12-425 CU. FT. (340-12,035 LITER)

Standard models are constructed of insulated carbon steel and contain no material hang-up points with solid internal walls. Value-added standard equipment includes heavy duty slide gate, convenient lifting lugs and hopper cover. No gaskets are used in the SD hoppers, which allows for a precision, laser cut door.

STANDARD FEATURES

- *Unique mass flow design*
- *Carbon steel construction with aluminum cover on the outside*
- *Integral welded carbon steel frame*
- *2" (5 cm) fiberglass insulation*
- *Hinged access door with long sight glass*
- *Inlet/outlet tube stubs should be specified when ordering*
- *Slide gate*
- *Drain port*



SD Series Drying Hopper

OPTIONAL FEATURES

- *Stainless steel construction inside and out*
- *Sensors, less controls: Single level RF-style sensor 115 or 230V; dual level RF-style sensor 115 or 230V; demand level sensor 115V*
- *Air-operated discharge slide gate, less controls*
- *Adapter to mount SRC 30/60 vacuum receiver onto SD 12-30 hopper models*

DIMENSIONS

Model	Size, cu. ft. (l)	Weight, lbs. (kg)	A	B	C	D	E	F	G	H	J
SD12	12 (340)	420 (191)	24	28	11	68	3	3	10	9	10 1/8
SD17	17 (481)	595 (270)	24	28	11	88	3	3	10	9	10 1/8
SD23	23 (651)	805 (365)	30	34	11	81	3	3	10	9	10 1/8
SD30	30 (850)	1050 (476)	30	34	11	99	3	3	10	9	10 1/8
SD45	45 (1274)	1575 (714)	40	44	15	100	5	5	16 1/4	12	17-1/8
SD60	60 (1699)	2100 (953)	40	44	35	120	5	5	16 1/4	12	17-1/8
SD75	75 (2124)	2625 (1191)	40	44	56	141	5	5	16 1/4	12	17-1/8
SD90	90 (2549)	3150 (1429)	50	54	23	126	8	5	16 1/4	12	17-1/8
SD135	135 (3823)	4725 (2143)	50	54	52	163	8	5	16 1/4	12	17-1/8
SD180	180 (5097)	6300 (2858)	64	68	63	156	8	5	16 1/4	12	17-1/8
SD240	240 (6796)	8400 (3810)	64	68	92	185	10	5	16 1/4	12	17-1/8
SD300	300 (8495)	10,500 (4763)	74	78	75	186	10	5	16 1/4	12	17-1/8
SD425	425 (12,035)	14,875 (6747)	74	78	114	225	10	5	16 1/4	12	17-1/8

Note: All dimensions are in inches

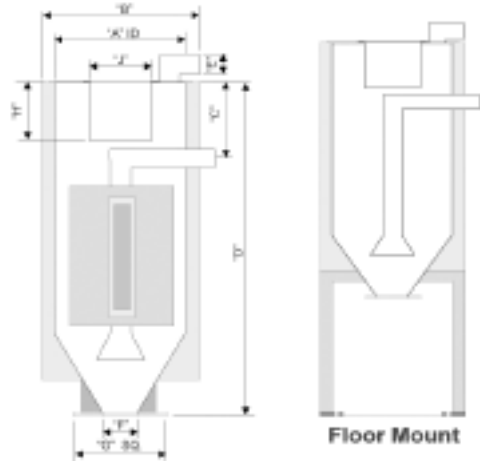

FLOOR STAND DIMENSIONS

Model	A	AA	B	BB	D (Std)	D (Gaylord)	E (Std)	E (Gaylord)
SD12	24	54	28	60	25	52	28	55
SD17	24	54	28	60	25	52	28	55
SD23	30	54	34	60	25	52	28	55
SD30	30	54	34	60	25	52	28	55
SD45	40	54	44	60	25	52	28	55
SD60	40	54	44	60	25	52	28	55
SD75	40	54	44	60	25	52	28	55
SD90	50	54	54	60	25	52	28	55
SD135	50	54	54	60	25	52	28	55
SD180	64	68	68	74	25	52	28	55
SD240	64	68	68	74	25	52	28	55
SD300	74	78	78	84	25	52	28	55
SD425	74	78	78	84	25	52	28	55

Note: All dimensions are in inches

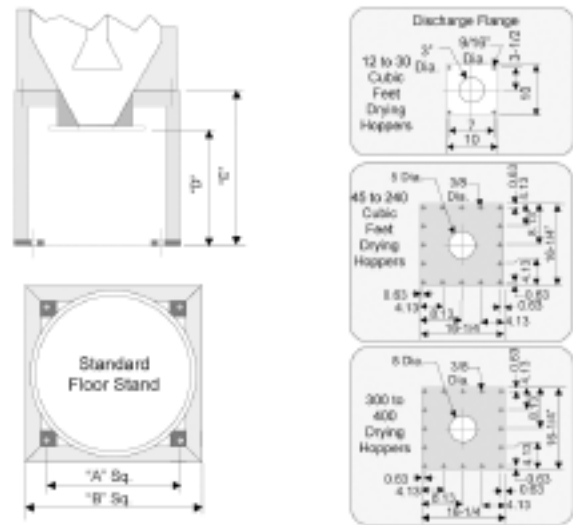

BOLT PLACEMENT

Model	A	B	C	D	E	F	G
SD12	1/4-20	6	11	10-1/8	28	5/8	23
SD17	1/4-20	6	11	10-1/8	28	5/8	23
SD23	1/4-20	6	11	10-1/8	34	5/8	29
SD30	1/4-20	6	11	10-1/8	34	5/8	29
SD45	1/4-20	6	18	17-1/8	44	5/8	39
SD60	1/4-20	8	18	17-1/8	44	5/8	39
SD75	1/4-20	8	18	17-1/8	44	5/8	39
SD90	1/4-20	8	18	17-1/8	54	5/8	49
SD135	1/4-20	8	18	17-1/8	54	5/8	49
SD180	1/4-20	8	18	17-1/8	68	5/8	63
SD240	1/4-20	8	18	17-1/8	68	5/8	63
SD300	1/4-20	8	18	17-1/8	78	5/8	73
SD425	1/4-20	8	18	17-1/8	78	5/8	73

Note: All dimensions are in inches

